

PROFESSIONAL LAUNDRY EQUIPMENT

HF 455

HF 575

HF 730

HF 900





HF 455 · HF 575 · HF 730 · HF 900

Star-shaped bearing housing

- Long life span of the bearings
- Oversized industrial design
- Equal diversion of the vibrations



Hinges

- Extra strong over-dimensioned hinges: long-life span

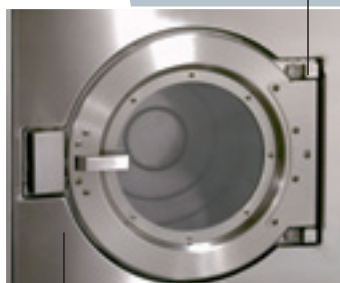

Door

- Extra large door opening for easy loading and unloading
- Strong ergonomical doorhandle
- 180° opening of the door

Drum

- Drum, tub and cabinet in stainless steel
- Performed lifting ribs



New: Tilting

- Easier and faster loading & unloading
-> Increased productivity
- Easier for a single person to operate machine
- Optionally available on all models
- Forward/backward tilting also available

IPSO: G-DRIVING THE INDUSTRY

Pulleys

- Pulleys in cast iron
- Speed sensor for exact rpm control



Microprocessor PS40

- Freely programmable
- 10 standard programmes
- 40 possible programmes
- Temperature, water level and cycle time freely programmable
- Connection up to 12 pumps for liquid soap
- Control of 2 drain valves (option)
- Infrared port facilitating the downloading of programmes



Bearing house

- Long life span of the bearings
- Cast iron
- Automatic lubrication

Practical soap dispenser

Standard front soap dispenser:

- 3 compartments
- 3 liquid soap pumps

Suspension

- Combination of shock absorbers and springs for maximum absorption



Injection pumps

- Standard: 3 liquid soap pumps
- Option: possibility to install up to 12 pumps



Sealing

- Automatic lubrication
- Triple sealing for total water tightness



Standard inverter drive

- Washing and spin speeds: freely programmable
- High G-forces
- Low sound level
- Rotation and stop speed programmes from 0,1 till 60 sec

front view 455-575

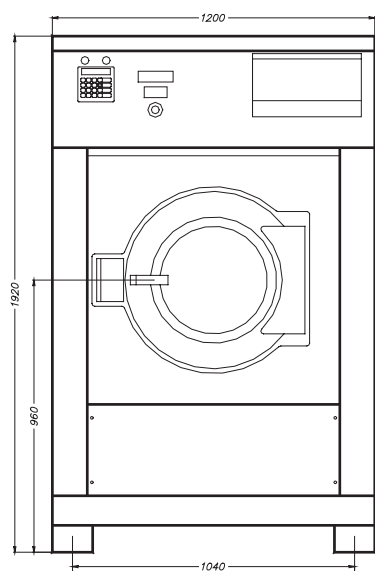

front view 730-900

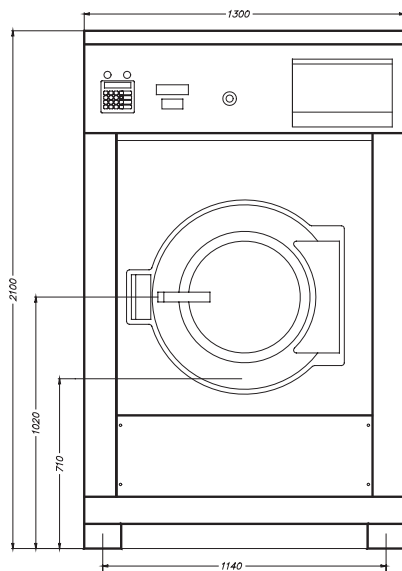

- A. Soft water connection 3/4"*
- B. Warm water connection 3/4"*
- C. Hard water connection 3/4"*
- D. Electrical connection
- E. Electrical connection clamps
- F. Main switch
- G. Ventilation cabinet
- H. Ventilation
- I. Steam connection 1/2"*
- J. Drain valve

* HF 730
 -> A-B-C: connection 1"
 -> I: connection 3/4"

rear view 455-575

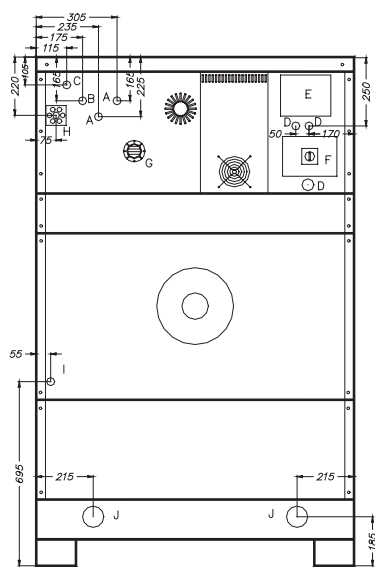

rear view 730-900

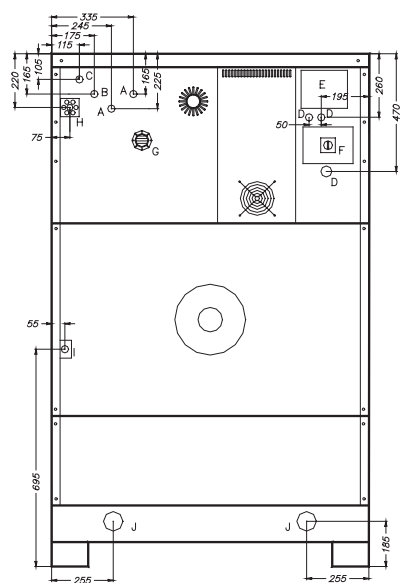

side view 455-575

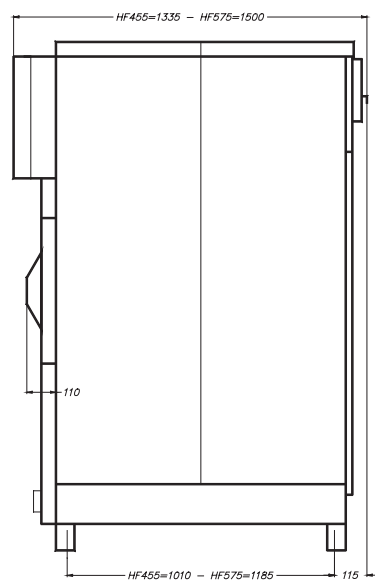

side view 730-900

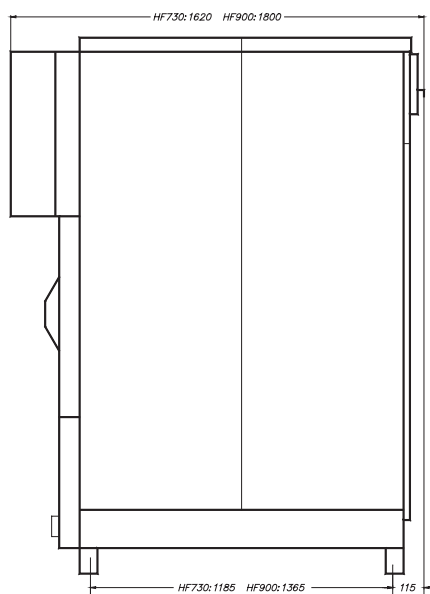

TECHNICAL SPECIFICATIONS HF 455-575-730-900

		HF 455	HF 575	HF 730	HF 900				
Cylinder:	Capacity 1/10 (kg)	45,5	57,5	73	90				
	Volume (L)	455	570	730	900				
	Diameter (mm)	980	980	1095	1095				
	Depth (mm)	597	775	775	957				
	Perforations diam. (mm)	3	3	3,5	3,5				
Door opening diam. (mm)		500	500	622	622				
Height to doorhandle (mm)		960	960	1020	1020				
Speed:	High spin (rpm)	500 to 800	500 to 800	500 to 750	500 to 750				
	Low spin (rpm)	250 to 400	250 to 400	250 to 400	250 to 400				
	Intermediate spin (rpm)	100	100	80	80				
	Wash (rpm)	10 to 50	10 to 50	10 to 50	10 to 50				
G-force		350	350	350	350				
Kinetic energy of the cylinder (N/m)		18361	23257	29581	29581				
Dynamic bottom load (N/13 Hz)		2960	3900	4960	6100				
Power motor (W (tri))		5500	7500	11500	11500				
Water pressure (bar)		3 to 5	3 to 5	3 to 5	3 to 5				
Hot water T° (boiler fed) (°C)		80	80	80	80				
Warm water need (boiler fed machine) (l/cycle)		350	445	566	566				
Heating:	Electrical 230 V (tri) (kW)	27	27	27	27				
	Electrical 400 V (tri + N) (kW)	27	27	27	27				
	Electrical 400 V (tri + N) (kW)	36	36	36	36				
Steam (kg/cycle)		45	57	70	90				
Diam. drain (mm/")		75 /3	75 /3	75/3 (2x)	75/3 (2x)				
Drain by gravity (L/min)		160	160	200	200				
Steam pressure (kg)		6 to 10	6 to 10	6 to 10	6 to 10				
Weight:	Nett (kg)	1697	1822	2100	2700				
	Gross (kg)	1520	1645	2350	3000				
Packing dimensions:	Height (mm)	2010	2010	2300	2300				
	Width (mm)	1300	1300	1450	1450				
	Depth (mm)	1430	1630	1720	1850				
	Volume (m³)	3,74	4,26	5,74	6,17				
Type of heating		POWER SUPPLY - FUSES							
		230V 3AC	400V (tri + N)	230V 3AC	400V (tri + N)	230V 3AC	400V (tri + N)	230V 3AC	400V (tri + N)
Boiler fed		20 A	20 A	20 A	20 A	20 A	20 A	20 A	20 A
Steam heating		20 A	20 A	20 A	20 A	20 A	20 A	20 A	20 A
Electrical heating 27 kW		80 A*	63 A	80 A*	63 A	80 A*	63 A	80 A*	63 A
Electrical heating 36 kW			80 A*		63 A*		80 A*		80 A*

All specifications subject to change without notice

[*] Standard heating



IPSO-LSG NV, NIEUWSTRAAT 146, B-8560 WEVELGEM (BELGIUM) TEL +32 56/41 20 54 - FAX +32 56/41 86 74

info@ipso.be - WWW.IPSO.BE



IPSO
- the commercial laundry division in
LSG, Laundry Systems Group

HF7301012006